



Drago America
www.dragoamerica.com

Project Name: _____

Location: _____

Item #: _____ Qty: _____

Model #: _____

SIA #

AIA #

Model:
DR78MGRH

Refrigerators – Merchandising Swing Glass Door

3 glass doors refrigerator 51 ft³



Features & Benefits

Strong & Durable Structure

- Coated steel exterior.
- Attractive aluminum liner with stainless steel floor interior.

Temperature

- Temperature range 33°F~40°F (0°C~4°C).

User Friendly Features

- Self-closing double pane glass door with a positive seal.
- Adjustable heavy duty PVC coated shelves.
- LED lighting.
- Electronic control system; easy adjust temperature set point and defrost frequency.
- Easy access to condenser coil for cleaning and service.

Refrigerant R290.



Certifications



Doors	Shelves	HP	AMPS	Crated Weight	Dimensions (inches)		
					W	D	H
3	12	4/5	8.4	672 Lb (305 Kg)	78.3" (1988 mm)	29.9" (760 mm)	80.7" (2050 mm)

Packaging dimensions: W 82.2" (2090 mm) x D 34.6" (880 mm) x H 87.4" (2220 mm).

Approvals:

Available At:

Model:
DR78MGRH

Refrigerators - Merchandising Swing Glass Door

3 glass doors refrigerator 51 ft³



Plan View

Front View

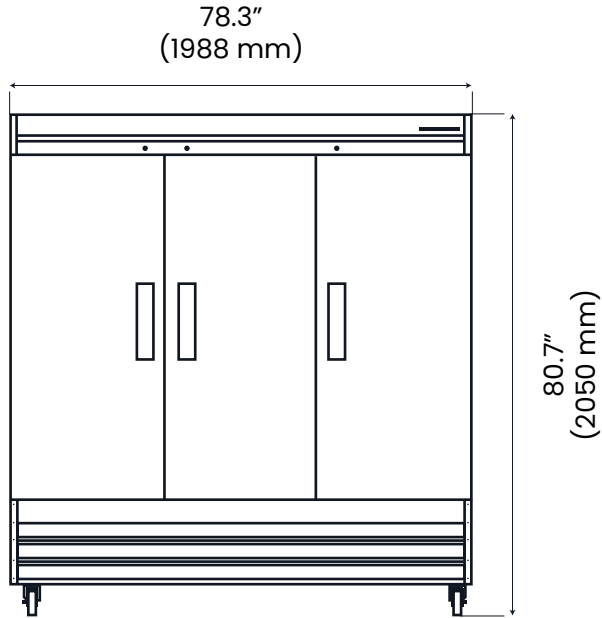

Side View

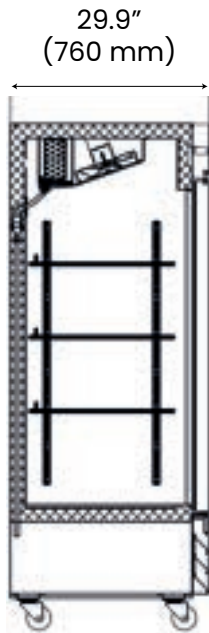

Spec

Electric Data

Voltage	115/60/1
Plug Type	NEMA 5-15P
Compressor HP	4/5
Refrigerant	R290

Dimensional Data

Capacity - cu. ft.	51 ft ³ (1445 liters)
Net Weight - Lbs.	613.8 Lbs. (279 Kg)

- Slight Variations May Exist



Drago America
www.dragoamerica.com
(346) 374-8343
9777 W. Gulf Bank Road Suite 200, Houston, Texas 77040