



Drago America  
www.dragoamerica.com

Project Name: \_\_\_\_\_

Location: \_\_\_\_\_

Item #: \_\_\_\_\_ Qty: \_\_\_\_\_

Model #: \_\_\_\_\_

SIA #

AIA #

Model:  
DRBC65

**Coolers – Bottle Cooler**  
17 ft<sup>3</sup>



**Features & Benefits**

**Strong & Durable Structure**

- Stainless steel top.
- Coated aluminum interior.
- Attractive corrosion resistant vinyl on steel in black finish on the exterior.

**Temperature**

- Temperature range 33°F~40°F (0°C~4°C).

**User Friendly Features**

- Removable bottle cap opener.
- Cap catcher included.
- Adjustable coated-steel dividers included.
- Easy access to condenser coil for cleaning and service.
- Easy adjust temperature set point and defrost frequency.

**Refrigerant R290.**



**Certifications**



Lids	HP	AMPS	Crated Weight	Dimensions (inches)		
				W	D	H
2	1/2	2.5	298 Lb (135 Kg)	64.5" (1638 mm)	28" (712 mm)	34.2" (869 mm)

Packaging dimensions: W 70" (1780 mm) x D 33" (830 mm) x H 43" (1085 mm).

Approvals:

Available At:

Model:  
DRBC65

## Coolers - Bottle Cooler

17 ft<sup>3</sup>



Plan View

Front View

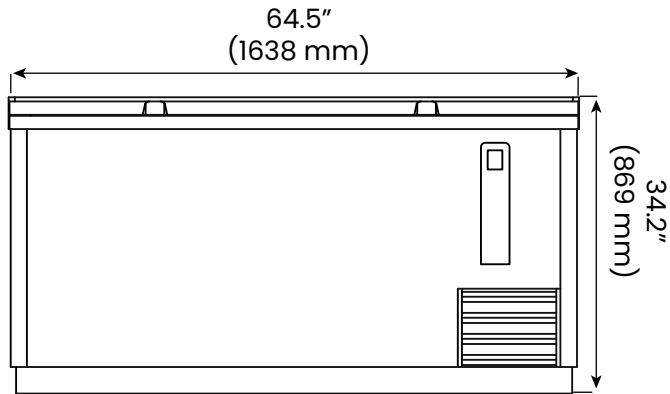

Side View

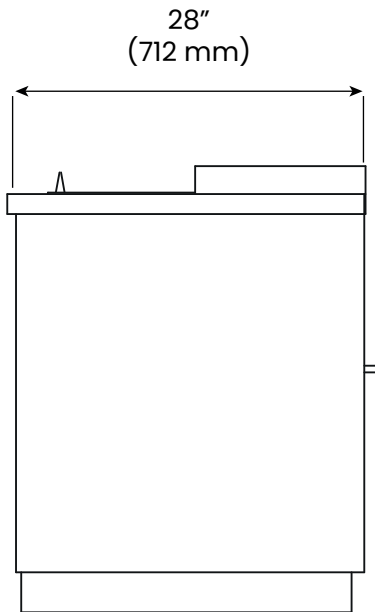

Spec

### Electric Data

Voltage	115/60/1
Plug Type	NEMA 5-15P
Compressor HP	1/2
Refrigerant	R290

### Dimensional Data

Capacity - cu. ft.	17 ft <sup>3</sup> (488 liters)
Net Weight - Lbs.	253 Lbs. (115 Kg)

- Slight Variations May Exist

# DRAGO

Drago America  
www.dragoamerica.com  
(346) 374-8343  
9777 W. Gulf Bank Road Suite 200, Houston, Texas 77040