



Drago America
www.dragoamerica.com

Project Name: _____

Location: _____

Item #: _____ Qty: _____

Model #: _____

SIA #

AIA #

Model:
DRBC95

Coolers – Bottle Cooler
28 ft³



**DRAGO
REGRIGATION**



Features & Benefits

Strong & Durable Structure

- Stainless steel top.
- Coated aluminum interior.
- Attractive corrosion resistant vinyl on steel in black finish on the exterior.

Temperature

- Temperature range 33°F~40°F (0°C~4°C).

User Friendly Features

- Removable bottle cap opener.
- Cap catcher included.
- Adjustable coated-steel dividers included.
- Easy access to condenser coil for cleaning and service.
- Easy adjust temperature set point and defrost frequency.

Refrigerant R290.



Certifications



Lids	HP	AMPS	Crated Weight	Dimensions (inches)		
				W	D	H
3	1/2	3.3	452 Lb (205 Kg)	95.2" (2418 mm)	28" (712 mm)	34.2" (869 mm)

Packaging dimensions: W 101" (2560 mm) x D 33" (830 mm) x H 43" (1085 mm).

Approvals:

Available At:

Model:
DRBC95

Coolers - Bottle Cooler

28 ft³



Front View

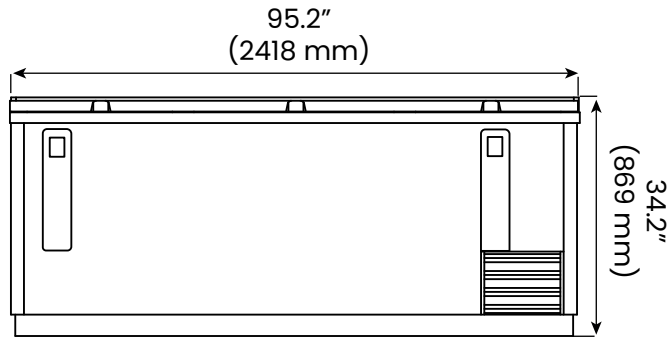

Side View

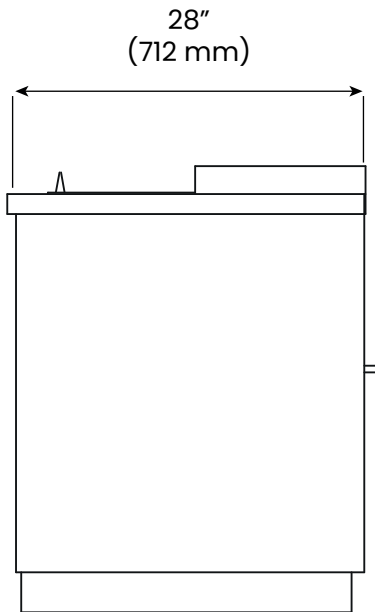

Electric Data	
Voltage	115/60/1
Plug Type	NEMA 5-15P
Compressor HP	1/2
Refrigerant	R290

Dimensional Data	
Capacity - cu. ft.	28 ft ³ (780 liters)
Net Weight - Lbs.	385 Lbs. (175 Kg)

- Slight Variations May Exist



Drago America
www.dragoamerica.com
(346) 374-8343
9777 W. Gulf Bank Road Suite 200, Houston, Texas 77040