



Drago America  
www.dragoamerica.com

Project Name: \_\_\_\_\_

Location: \_\_\_\_\_

Item #: \_\_\_\_\_ Qty: \_\_\_\_\_

Model #: \_\_\_\_\_

SIA #

AIA #

Model:  
DRCB36

**Chef Base**  
6 ft<sup>3</sup>



**Features & Benefits**

**Strong & Durable Structure**

- Stainless steel interior and exterior.
- Matching aluminium finished back.

**Temperature**

- Temperature range 33°F ~ 40°F (0°C ~ 4°C).

**User Friendly Features**

- Preinstalled heavy-duty casters.
- Heavy-duty pull handles.
- Electronic control system; easy adjust temperature set point and defrost frequency.
- Easy access to condenser coil for cleaning and service.

**Refrigerant R290.**



**Certifications**



Drawers	HP	AMPS	Crated Weight	Dimensions (inches)		
				W	D	H
2	1/3	4	225 Lbs (102 Kg)	36.4" (924 mm)	32.1" (880 mm)	25.9" (657 mm)

Packaging dimensions (mm): W 39" (994) x D 35" (886) x H 28.5" (725)

Approvals:

Available At:

Model:

# Chef Base

## DRCB36



### Front View

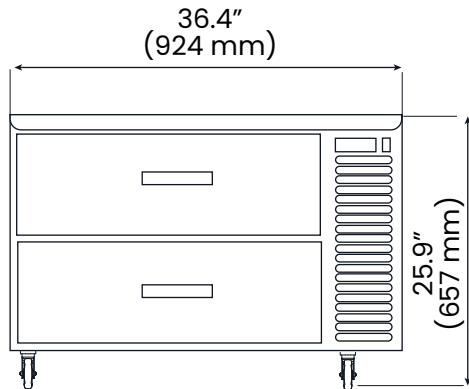

### Side View

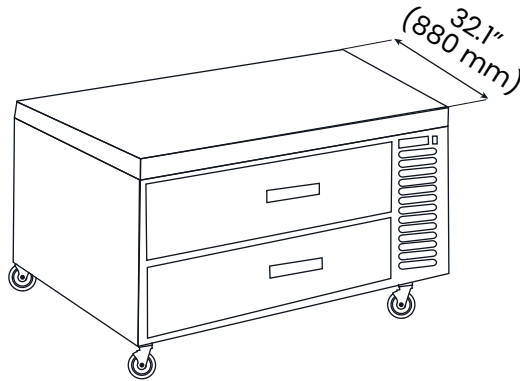

### Electric Data

Electric Data	
Voltage	115/60/1
Plug Type	NEMA 5-15P
Compressor HP	1/3
Refrigerant	R290

### Dimensional Data

Dimensional Data	
Capacity - cu. ft.	6 ft <sup>3</sup> (162 liters)
Net Weight - Lbs.	165 Lbs (75 Kg)

- Slight Variations May Exist



Drago America  
www.dragoamerica.com  
(346) 374-8343  
9777 W. Gulf Bank Road Suite 200, Houston, Texas 77040