



Drago America  
www.dragoamerica.com

Project Name: \_\_\_\_\_

Location: \_\_\_\_\_

Item #: \_\_\_\_\_ Qty: \_\_\_\_\_

Model #: \_\_\_\_\_

SIA #

AIA #

Model:  
DRDK23

## Kegeators – Direct Draw Beer Dispenser

7 ft<sup>3</sup>



### Features & Benefits

#### Strong & Durable Structure

- Stainless steel top, interior walls, floor and ceiling.
- Attractive corrosion resistant vinyl on steel in black finish on the exterior.

#### Temperature

- Temperature range 33°F~40°F (0°C~4°C).

#### User Friendly Features

- Self-Closing doors with locks.
- LED interior lighting.
- Adjustable heavy-duty PVC coated shelves.
- Easy access to condenser coil for cleaning and service.
- Easy adjust temperature set point and defrost frequency.

**Preinstalled heavy-duty casters with brakes.**

**Refrigerant R290.**

### Certifications



Doors	Shelves	HP	AMPS	Crated Weight	Dimensions (inches)		
					W	D	H
1	2	1/4	1.92	176 Lb (80 Kg)	23.5" (596 mm)	30.2" (767 mm)	39.8" (1011 mm)

Packaging dimensions: W 26" (660 mm) x D 32" (820 mm) x H 45" (1140 mm).

Approvals:

Available At:

Model:  
DRDK23

# Kegeators - Direct Draw Beer Dispenser

7 ft<sup>3</sup>



Plan View

Front View

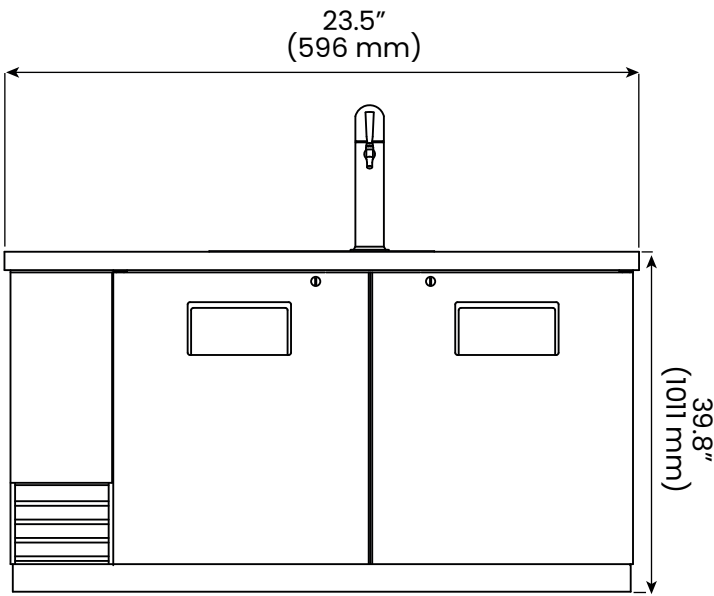

Side View

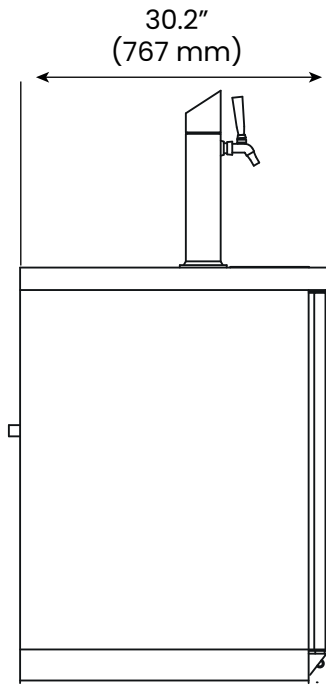

Spec

## Electric Data

Voltage	115/60/1
Plug Type	NEMA 5-15P
Compressor HP	1/4
Refrigerant	R290

## Dimensional Data

Capacity - cu. ft.	7 ft <sup>3</sup> (200 liters)
Net Weight - Lbs.	132 Lbs. (60 Kg)

- Slight Variations May Exist

# DRAGO

Drago America  
www.dragoamerica.com  
(346) 374-8343

9777 W. Gulf Bank Road Suite 200, Houston, Texas 77040