



Drago America
www.dragoamerica.com

Project Name: _____

Location: _____

Item #: _____ Qty: _____

Model #: _____

SIA #

AIA #

Model:
DRDK90

Kegeators – Direct Draw Beer Dispenser

28 ft³



Features & Benefits

Strong & Durable Structure

- Stainless steel top, interior walls, floor and ceiling.
- Attractive corrosion resistant vinyl on steel in black finish on the exterior.

Temperature

- Temperature range 33°F~40°F (0°C~4°C).

User Friendly Features

- Self-Closing doors with locks.
- LED interior lighting.
- Adjustable heavy-duty PVC coated shelves.
- Easy access to condenser coil for cleaning and service.
- Easy adjust temperature set point and defrost frequency.

Preinstalled heavy-duty casters with brakes.

Refrigerant R290.



Certifications



| Doors | Shelves | HP | AMPS | Crated Weight | Dimensions (inches) | | |
|-------|---------|-----|------|--------------------|---------------------|-------------------|-------------------|
| | | | | | W | D | H |
| 3 | 6 | 1/2 | 4.1 | 408 Lb (185 Kg) | 90.4" (2295 mm) | 27.8" (705 mm) | 35.6" (905 mm) |

Packaging dimensions: W 92" (2330 mm) x D 30.5" (775 mm) x H 42" (1070 mm).

Approvals:

Available At:

Model:
DRDK90

Kegeators - Direct Draw Beer Dispenser

28 ft³



Plan View

Front View

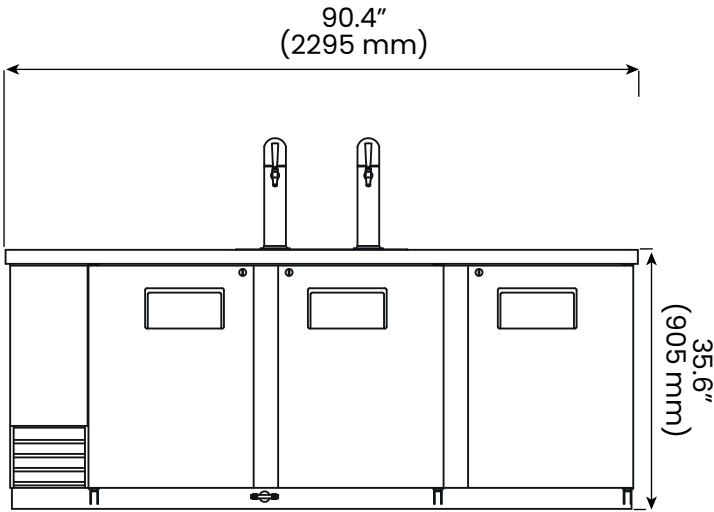

Side View

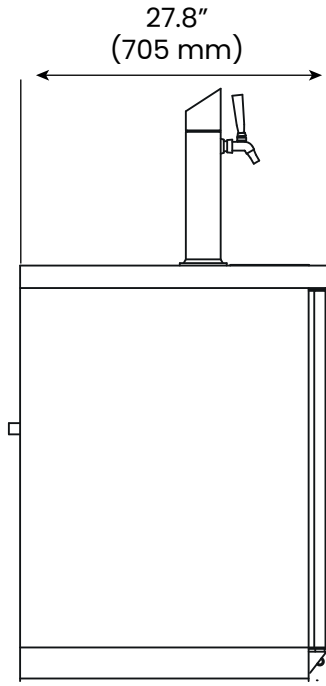

Spec

Electric Data

| | |
|---------------|------------|
| Voltage | 115/60/1 |
| Plug Type | NEMA 5-15P |
| Compressor HP | 1/2 |
| Refrigerant | R290 |

Dimensional Data

| | |
|--------------------|---------------------------------|
| Capacity - cu. ft. | 28 ft ³ (805 liters) |
| Net Weight - Lbs. | 363 Lbs. (165 Kg) |

- Slight Variations May Exist



Drago America
www.dragoamerica.com
(346) 374-8343
9777 W. Gulf Bank Road Suite 200, Houston, Texas 77040