



Drago America
www.dragoamerica.com

Project Name: _____

SIA #

Location: _____

Item #: _____ Qty: _____

AIA #

Model #: _____

Model:
DRGM24

Griddle
24" - Propane Gas



Features & Benefits

Strong & Durable Structure

- Stainless steel front, sides, splash guard and plating zone.
- Heavy duty metal knobs with heat protection grips.

Burners:

- Stainless steel J burner with a capacity of 30,000 Btu/hr each.
- One burner per section of 12" (305 mm) with an individual control.
- One pilot per burner for instant ignition.

Griddle plate:

- Highly polished 1/2-inch thick steel plate maintains temperature and recovers quickly.
- Total working area of the 20" (506 mm) plate for increased cooking surface and high production performance.
- Splash guard frame for easy cleaning.

Grease traps:

- Stainless steel structure that prevents corrosion from food moisture.
- Removable crumb tray for easy cleaning.



Certifications



22/04/2024

Burners	Gas Output	Griddle Dimensions			Net Weight
		L	W	H	
2	60,000 Btu/hr	24" (610 mm)	30" (762 mm)	14" (355 mm)	115 Lb (52 Kg)

Approvals:

Available At:

Model:
DRGM24

Griddle

24" - Propane Gas



Plan View

Front View

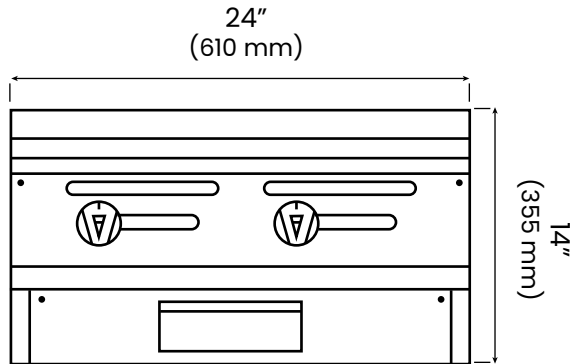

Side View

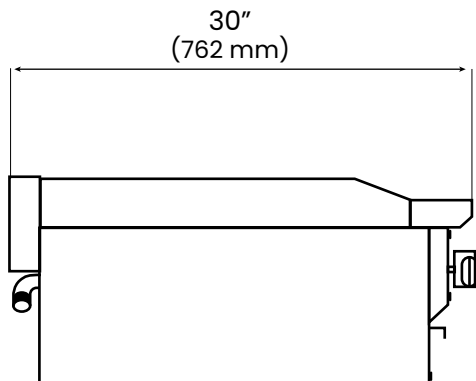

Spec

Gas Specifications:

Gas Type:	Propane gas
Manifold pressure:	11" W.C.
Gas connection:	3/4".
<i>*Specify type of gas and elevation if over 2000 ft.</i>	

Packaging data:

Dimensions:	L 26.7" (680 mm) W 32.2" (820 mm) H 20.4" (520 mm)
Crated weight:	121 Lb (55 Kg)

- Slight variations may exist.



Drago America
www.dragoamerica.com
(346) 374-8343
9777 W. Gulf Bank Road Suite 200, Houston, Texas 77040