



Drago America
www.dragoamerica.com

Project Name: _____

SIA #

Location: _____

Item #: _____ Qty: _____

AIA #

Model #: _____

Model:
DRHP12

Hot Plate
12" - Propane Gas



Features & Benefits

Strong & Durable Structure

- Stainless steel front, sides, plating zone and landing ledge.
- Welded and polished stainless steel seams.
- Large 4" (100 mm) stainless steel plating zone.
- Heavy duty metal knobs with heat protection grips.
- Removable crumb tray for easy cleaning.

Open Burners:

- Cast iron burners with a capacity of 26,300 Btu/hr with two rings of flame for even heating.
- Anti-clogging, lift off and separate for easy cleaning.
- No gaskets or screws.
- One standing pilot per burner for instant ignition.

Grates:

- 12" x 12" (305 mm x 305 mm) grates measures.
- Cast iron structure for a long service life.
- Sections are easy and safe to lift-off for cleaning.



Certifications



22/04/2024

Burners	Gas Output	Griddle Dimensions			Net Weight
		L	W	H	
2	60,000 Btu/hr	12" (305 mm)	30" (762 mm)	14" (355 mm)	69 Lb (31 Kg)

Approvals:

Available At:

Model:
DRHP12

Hot Plate

12" - Propane Gas



Plan View

Front View

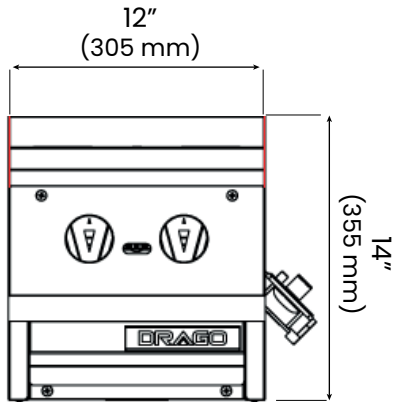

Side View

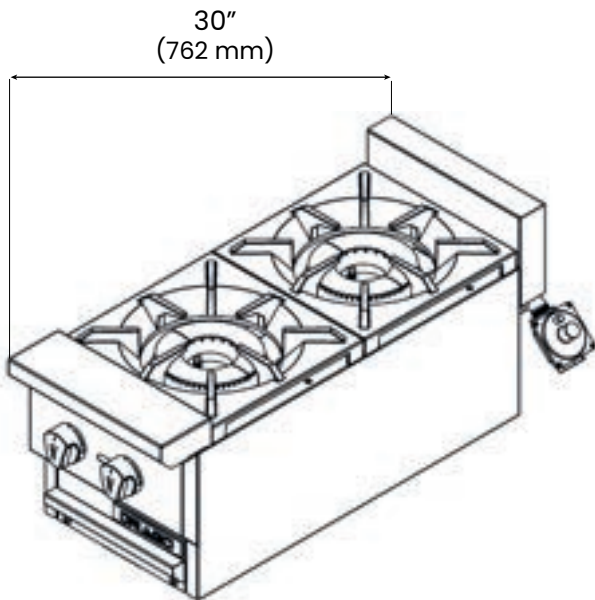

Spec

Gas Specifications:

Gas Type:	Propane gas
Manifold pressure:	11" W.C.
Gas connection:	3/4"
<i>*Specify type of gas and elevation if over 2000 ft.</i>	

Packaging data:

Dimensions:	L 13.7" (350 mm) W 32.2" (820 mm) H 20.4" (520 mm)
Crated weight:	77 Lb (35 Kg)

- Slight variations may exist.

DRAGO

Drago America
www.dragoamerica.com
(346) 374-8343

9777 W. Gulf Bank Road Suite 200, Houston, Texas 77040