



Drago America  
www.dragoamerica.com

Project Name: \_\_\_\_\_

SIA #

Location: \_\_\_\_\_

Item #: \_\_\_\_\_ Qty: \_\_\_\_\_

AIA #

Model #: \_\_\_\_\_

Model:  
DRHP36

**Hot Plate**  
36" - Propane Gas



**Features & Benefits**

**Strong & Durable Structure**

- Stainless steel front, sides, plating zone and landing ledge.
- Welded and polished stainless steel seams.
- Large 4" (100 mm) stainless steel plating zone.
- Heavy duty metal knobs with heat protection grips.
- Removable crumb tray for easy cleaning.

**Open Burners:**

- Cast iron burners with a capacity of 26,300 Btu/hr with two rings of flame for even heating.
- Anti-clogging, lift off and separate for easy cleaning.
- No gaskets or screws.
- One standing pilot per burner for instant ignition.

**Grates:**

- 12" x 12" (305 mm x 305 mm) grates measures.
- Cast iron structure for a long service life.
- Sections are easy and safe to lift-off for cleaning.

**Certifications**



22/04/2024

Burners	Gas Output	Griddle Dimensions			Net Weight
		L	W	H	
6	180,000 Btu/hr	36" (914 mm)	30" (762 mm)	14" (355 mm)	168 Lb (76 Kg)

Approvals:

Available At:

Model:  
**DRHP36**

## Hot Plate

36" - Propane gas



Plan View

Front View

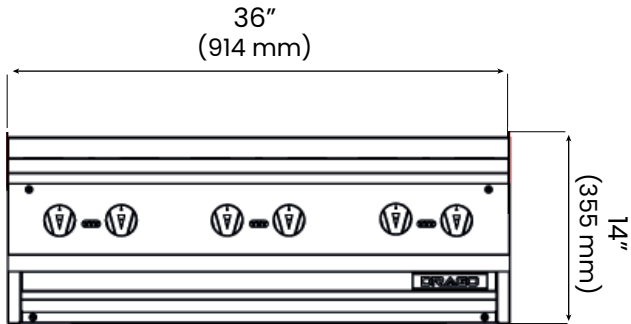

Side View

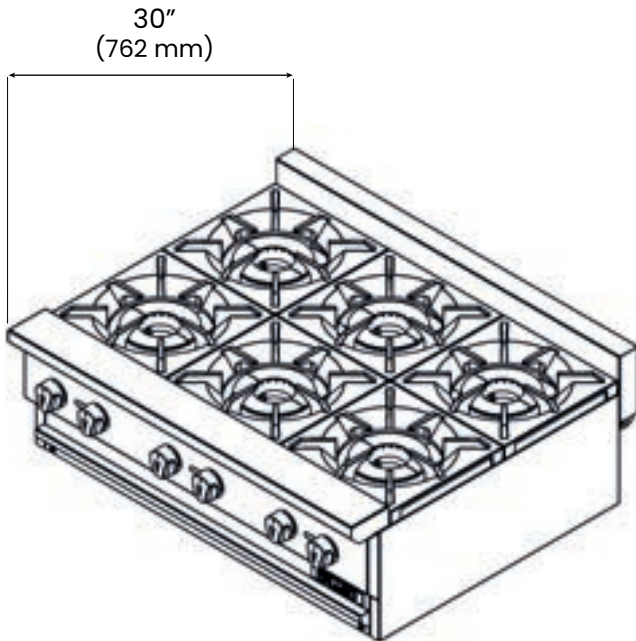

Spec

### Gas Specifications:

Gas Type:	Propane gas
Manifold pressure:	11" W.C.
Gas conexion:	3/4"
<i>*Specify type of gas and elevation if over 2000 ft.</i>	

### Packaging data:

Dimensions:	L 38.5" (980 mm) W 32.2" (820 mm) H 20.4" (520 mm)
Crated weight:	180.7 Lb (82 Kg)

- Slight variations may exist.

# DRAGO

Drago America  
[www.dragoamerica.com](http://www.dragoamerica.com)

(346) 374-8343

9777 W. Gulf Bank Road Suite 200, Houston, Texas 77040