



Drago America
www.dragoamerica.com

Project Name: _____

Location: _____

Item #: _____ Qty: _____

Model #: _____

SIA #

AIA #

Model:
DRPP49

Prep Tables – Pizza Prep Table

1 solid door 10 ft³



**DRAGO
REGRIGATION**



Features & Benefits

Strong & Durable Structure

- Stainless steel interior and exterior, aluminum back.

Temperature

- Temperature range 33°F~40°F (0°C~4°C).

User Friendly Features

- Self-closing doors with 90 degree stay-open feature.
- Adjustable heavy duty PVC coated shelves.
- Easy access to condenser coil for cleaning and service.
- Easy adjust temperature set point and defrost frequency.

Pre-installed heavy-duty casters with brakes.

Refrigerant R290.



Certifications



Doors	Shelves	Pans	Pans Size	HP	AMPS	Crated Weight	Dimensions (inches)		
							W	D	H
1	1	6	1/3	1/3	3.36	396.8 Lb (180 Kg)	49.8" (1264 mm)	31.5" (800 mm)	39.4" (1002 mm)

Packaging dimensions: W 55.1" (1400 mm) x D 36.6" (930 mm) x H 45.8" (1165 mm).

Approvals:

Available At:

Model:
DRPP49

Prep Tables – Pizza Prep Table

1 solid door 10 ft³



Plan View

Front View

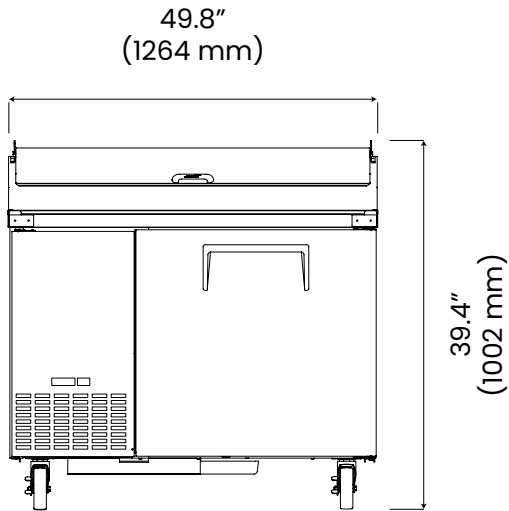

Side View

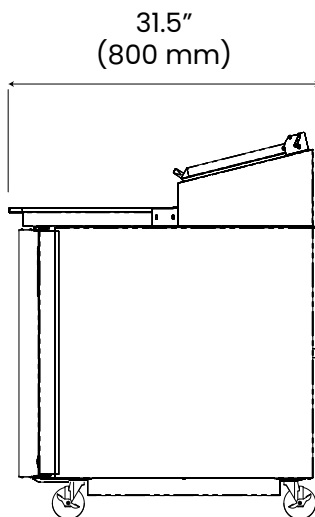

Spec

Electric Data

Voltage	115/60/1
Plug Type	NEMA 5-15P
Compressor HP	1/3
Refrigerant	R290

Dimensional Data

Capacity - cu. ft.	10 ft ³ (270 liters)
Net Weight - Lbs.	286 Lbs. (130 Kg)

- Slight Variations May Exist



Drago America
www.dragoamerica.com
(346) 374-8343

9777 W. Gulf Bank Road Suite 200, Houston, Texas 77040