



Drago America  
www.dragoamerica.com

Project Name: \_\_\_\_\_

Location: \_\_\_\_\_

Item #: \_\_\_\_\_ Qty: \_\_\_\_\_

Model #: \_\_\_\_\_

SIA #

AIA #

Model:  
DRPP70

## Prep Tables – Pizza Prep Table

1 solid door 17 ft<sup>3</sup>



**DRAGO  
REGRIGATION**



### Features & Benefits

#### Strong & Durable Structure

- Stainless steel interior and exterior, aluminum back.

#### Temperature

- Temperature range 33°F~40°F (0°C~4°C).

#### User Friendly Features

- Self-closing doors with 90 degree stay-open feature.
- Adjustable heavy duty PVC coated shelves.
- Easy access to condenser coil for cleaning and service.
- Easy adjust temperature set point and defrost frequency.

**Pre-installed heavy-duty casters with brakes.**

**Refrigerant R290.**



### Certifications



| Doors | Shelves | Pans | Pans Size | HP  | AMPS | Crated Weight        | Dimensions (inches) |                   |                    |
|-------|---------|------|-----------|-----|------|----------------------|---------------------|-------------------|--------------------|
|       |         |      |           |     |      |                      | W                   | D                 | H                  |
| 2     | 2       | 9    | 1/3       | 1/2 | 5.52 | 476.1 Lb<br>(216 Kg) | 70.9"<br>(1800 mm)  | 31.5"<br>(800 mm) | 39.4"<br>(1002 mm) |

Packaging dimensions: W 75.9" (1930 mm) x D 36.6" (930 mm) x H 45.8" (1165 mm).

Approvals:

Available At:

Model:  
DRPP70

## Prep Tables - Pizza Prep Table

1 solid door 17 ft<sup>3</sup>



Plan View

Front View

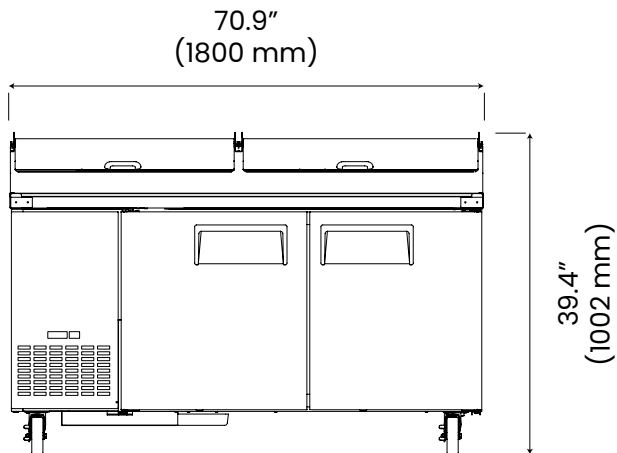

Side View

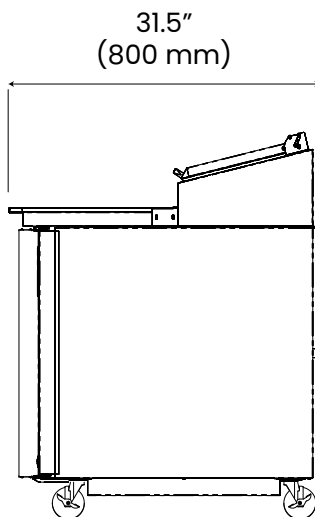

Spec

### Electric Data

|               |            |
|---------------|------------|
| Voltage       | 115/60/1   |
| Plug Type     | NEMA 5-15P |
| Compressor HP | 1/2        |
| Refrigerant   | R290       |

### Dimensional Data

|                    |                                 |
|--------------------|---------------------------------|
| Capacity - cu. ft. | 17 ft <sup>3</sup> (477 liters) |
| Net Weight - Lbs.  | 341 Lbs. (155 Kg)               |

- Slight Variations May Exist

# DRAGO

Drago America  
www.dragoamerica.com  
(346) 374-8343

9777 W. Gulf Bank Road Suite 200, Houston, Texas 77040