



Drago America
www.dragoamerica.com

Project Name: _____

Location: _____

Item #: _____ Qty: _____

Model #: _____

SIA #

AIA #

Model:
DRSP72-27M

Prep Tables – Megatop Sandwich Prep Table

3 solid doors 20 ft³



**DRAGO
REGRIGATION**



Features & Benefits

Strong & Durable Structure

- Stainless steel interior and exterior, aluminum back.

Temperature

- Temperature range 33°F~40°F (0°C~4°C).

User Friendly Features

- Self-closing doors with 90 degree stay-open feature.
- Adjustable heavy duty PVC coated shelves.
- Easy access to condenser coil for cleaning and service.
- Easy adjust temperature set point and defrost frequency.

Pre-installed heavy-duty casters with brakes.

Refrigerant R290.



Certifications



| Doors | Shelves | Pans | Pans Size | HP | AMPS | Crated Weight | Dimensions (inches) | | |
|-------|---------|------|-----------|-----|------|----------------------|---------------------|-----------------|--------------------|
| | | | | | | | W | D | H |
| 3 | 3 | 27 | 1/6 | 2/3 | 7.8 | 416.6 Lb (189 Kg) | 70.4" (1787 mm) | 34" (864 mm) | 45.1" (1146 mm) |

Packaging dimensions: W 75.5" (1920 mm) x D 39.1" (995 mm) x H 49.1" (1248 mm).

Approvals:

Available At:

Model:
DRSP72-27M

Prep Tables – Megatop Sandwich Prep Table

3 solid doors 20 ft³



Front View

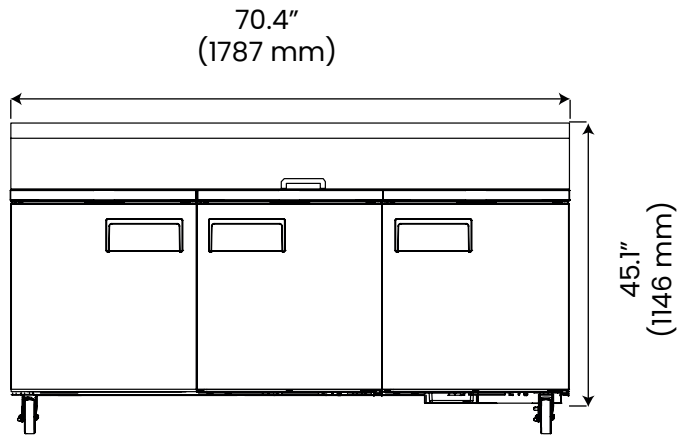

Side View

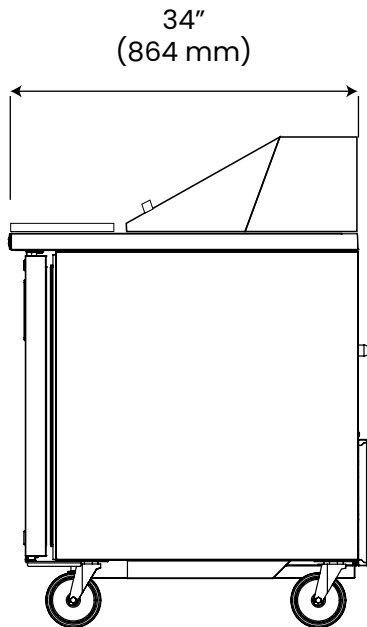

Electric Data

| | |
|---------------|------------|
| Voltage | 115/60/1 |
| Plug Type | NEMA 5-15P |
| Compressor HP | 2/3 |
| Refrigerant | R290 |

Dimensional Data

| | |
|--------------------|---------------------------------|
| Capacity - cu. ft. | 20 ft ³ (553 liters) |
| Net Weight - Lbs. | 374 Lbs. (170 Kg) |

- Slight Variations May Exist

DRAGO

Drago America
www.dragoamerica.com
(346) 374-8343
9777 W. Gulf Bank Road Suite 200, Houston, Texas 77040