



Drago America  
www.dragoamerica.com

Project Name: \_\_\_\_\_

Location: \_\_\_\_\_

Item #: \_\_\_\_\_ Qty: \_\_\_\_\_

Model #: \_\_\_\_\_

SIA #

AIA #

Model:  
DRUC27R

## Refrigerators – Undercounter Refrigerator

1 solid door 5 ft<sup>3</sup>



### Features & Benefits

#### Strong & Durable Structure

- Stainless steel interior and exterior, aluminum back.
- Option of bright white aluminum interior available.

#### Temperature

- Temperature range 33°F~40°F (0°C~4°C).

#### User Friendly Features

- Self-closing solid doors.
- Option of stainless steel exterior available.
- Adjustable heavy duty PVC coated shelves.
- Easy access to condenser coil for cleaning and service.
- Easy adjust temperature set point and defrost frequency.
- Option of Backsplashes and different handles available.

**Pre-installed heavy-duty casters with brakes.**

**Refrigerant R290.**



### Certifications



Doors	Shelves	HP	AMPS	Crated Weight	Dimensions (inches)		
					W	D	H
1	1	1/3	1.8	180.7 lb (82 Kg)	27" (685 mm)	29.5" (750 mm)	35.2" (895 mm)

Packaging dimensions inch(mm): W 29.7" (755) x D 32.3" (820) x H 38.6" (980)

Approvals:

Available At:

Model:  
DRUC27R

## Refrigerators - Undercounter Refrigerator

1 solid door 5 ft<sup>3</sup>



Front View

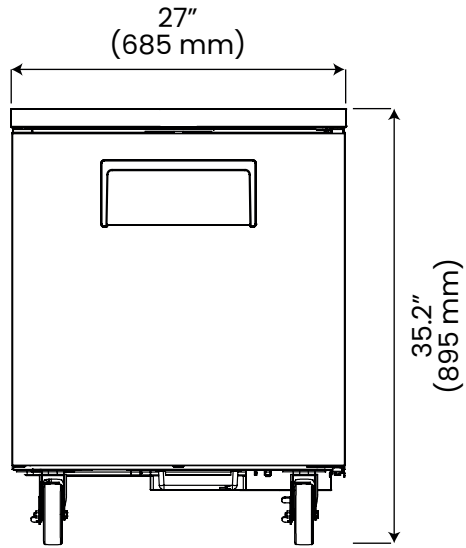

Side View

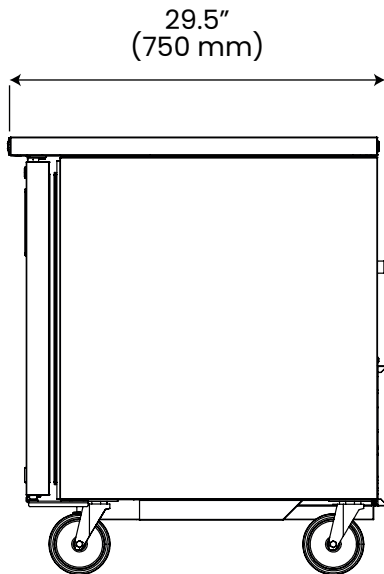

### Electric Data

Voltage	115/60/1
Plug Type	NEMA 5-15P
Compressor HP	1/3
Refrigerant	R290

### Dimensional Data

Capacity - cu. ft.	5 ft <sup>3</sup> (154 liters)
Net Weight - Lbs.	158.4 Lbs. (72 Kg)

- Slight Variations May Exist

# DRAGO

Drago America  
www.dragoamerica.com  
(346) 374-8343

9777 W. Gulf Bank Road Suite 200, Houston, Texas 77040