



Drago America
www.dragoamerica.com

Project Name: _____

Location: _____

Item #: _____ Qty: _____

Model #: _____

SIA #

AIA #

Model:
DRUC72R

Refrigerators – Undercounter Refrigerator

3 solid doors 17 ft³



Features & Benefits

Strong & Durable Structure

- Stainless steel interior and exterior, aluminum back.
- Option of bright white aluminum interior available.

Temperature

- Temperature range 33°F~40°F (0°C~4°C).

User Friendly Features

- Self-closing solid doors.
- Option of stainless steel exterior available.
- Adjustable heavy duty PVC coated shelves.
- Easy access to condenser coil for cleaning and service.
- Easy adjust temperature set point and defrost frequency.
- Option of Backsplashes and different handles available.

Pre-installed heavy-duty casters with brakes.

Refrigerant R290.



Certifications



Doors	Shelves	HP	AMPS	Crated Weight	Dimensions (inches)		
					W	D	H
3	3	1/3	2.7	337.3 Lb (153 Kg)	71.5" (1815 mm)	29.5" (750 mm)	35.2" (895 mm)

Packaging dimensions (mm): W 74.2" (1885) x D 32.3" (820) x H 38.6" (980)

Approvals:

Available At:

Model:
DRUC72R

Refrigerators - Undercounter Refrigerator

3 solid doors 17 ft³



Plan View

Front View

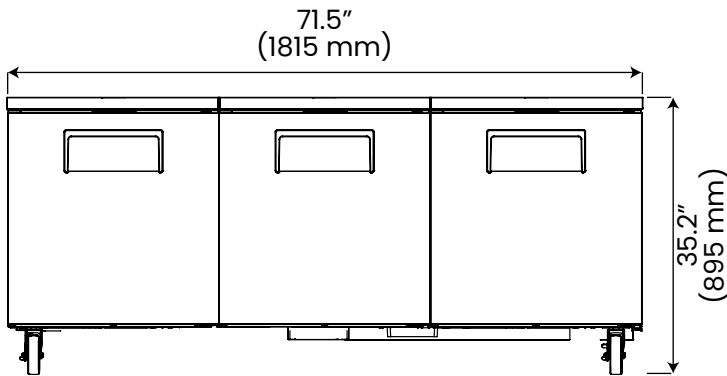

Spec

Electric Data	
Voltage	115/60/1
Plug Type	NEMA 5-15P
Compressor HP	1/3
Refrigerant	R290

Dimensional Data	
Capacity - cu. ft.	17 ft ³ (481 liters)
Net Weight - Lbs.	297 Lbs. (135 Kg)

- Slight Variations May Exist

Side View

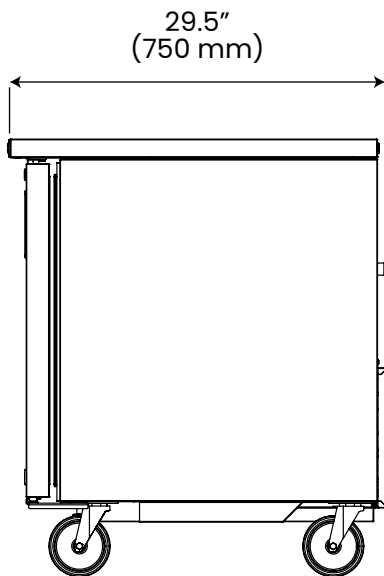

DRAGO

Drago America
www.dragoamerica.com
(346) 374-8343

9777 W. Gulf Bank Road Suite 200, Houston, Texas 77040